

Butzbach GmbH
 Industrietore
 Weiherstraße 16
 89293 Kellmünz (Germany)

Tel. +49 8337 901-0
 Fax +49 8337 901-49
 info@butzbach.com
 www.butzbach.com

Technical Data SPACELITE® HT 60 H

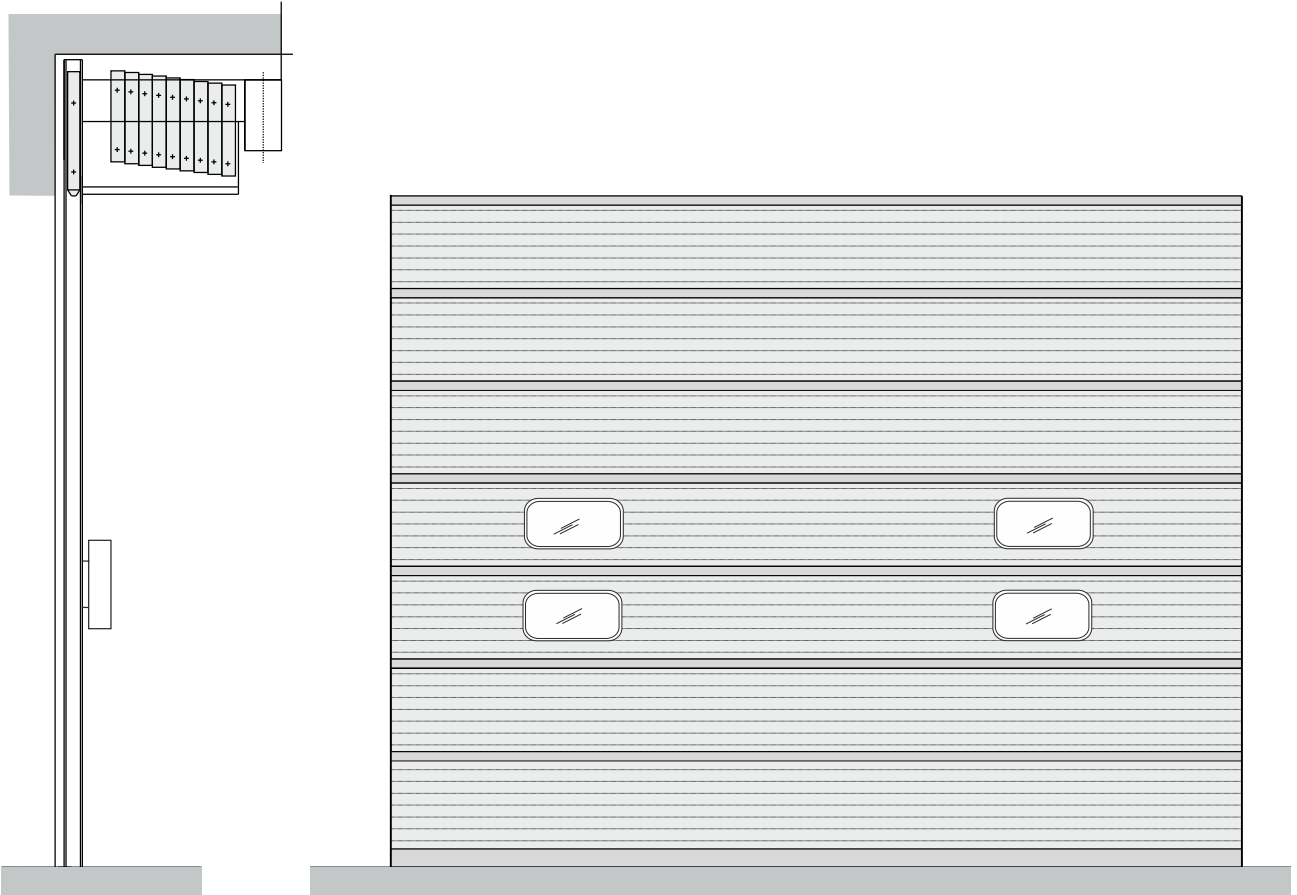

Mounting- and fixing modes

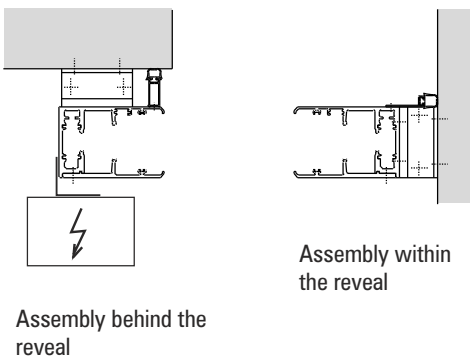

Assembly behind the reveal

Assembly within the reveal

Technical Data

Door panel depth (mm)	60
Door panel height (mm)	approx. 1000
Maximum door width (mm)	7500
Lintel height required (mm)*	1250
Door operation in self-holding circuit	■
Vision panel made of acrylic glass	-
Ovals window	●
Anti-drop device	■
Overload protection for drive unit	■
Safety edge control	■
Aluminium profiles colour coated	●
Aluminium profiles anodised	●

■ = basic equipment
 ● = available

* Please contact us, if the necessary lintel height is not available. We can offer other technical solutions. For large door height dimensions the lintel height can exceed the above given value.

We have detailed technical drawings with the necessary installation dimensions for each door type at your disposal.

Technical Data SPACELITE® HT 60

Mains connection	(supplied by contractor) 400 V/ 50 Hz, pre-fuse 10 A three-phase current automation. Doors with frequency converter: 230 V/ 50 Hz, 16 A via one-phase current automation. Make sure the residual current-operated circuit breaker is designed for both: Residual alternating current and residual pulsating direct current with a residual current not less than 300 mA. Note! The operator is responsible for the door inspection according to VDE 0100-610 or IEC 60364-6-61 respectively. For a three-phase current connection a »clockwise rotating field« has to be applied.
Drive unit.	Electrical drive unit, including thermal overload protection, protection class IP 54, driving power depending on size and equipment of the door: Between 0.85 kW and 1.35 kW.
Control voltage	24 VDC
Control system	The microprocessor control is located inside a plastic housing (w182 x h370 x d90 mm), protection class IP 54. An OPEN/STOP/DOWN button for door operation and the main switch separating all poles are located on the control panel front. The control system will normally be attached to the track at operating height. In automatic operation the door can be opened and closed in self-holding circuit either by a push button or via a signal encoder. A sufficient number of connection clamps and a 24 VDC power supply are provided to connect a photo eye for passage control. Two output relays can be set, e.g. for a potential-free indication door open/door closed, to trigger traffic lights and signal indicators or the courtyard light function. Operating states are indicated.
Door panels	Door panel height: HT 60N approx. 500 mm, HT 60H approx. 1000 mm. Twin-walled fibreglass panels, available in the colour shades brilliant, emerald-green, sapphire-blue (option), aluminium profiles (option: RAL colour-coated or anodised according to DIN 17611) and rubber sealings; side profiles with guide rollers. Light transmission: up to 78 % (dependent on colour and thermal insulation). U_p -value twin-walled fibreglass panels = 2.5 W/m ² K. Option: U_p -value improvement to approx. 1.1 W/m ² K. Note! Due to the laws of physics, twin-walled fibreglass panels are not diffusion-proof.
Tracks	Aluminium solid (optionally RAL colour-coated or anodised according to DIN 17611), with removable track covers; rolled-in, galvanised safety rails for the anti-drop device; integrated buzzbar and brush profiles.
Cassettes	Made of galvanised steel, including drive tube, safety rail and driving mechanism.
Speed	Opening- and closing speed up to 15 cm/s.
Door sealing	With rubber seals between the individual door panels, between tracks and door panels with brush profiles, towards lintel and reveal with rubber seal lips, towards the floor with a double rubber profile.
Safety	Anti-drop device tested by TÜV (German technical surveillance agency), complying with the regulations of the German employer's liability insurance association. The mechanical elements are integrated inside the tracks. Safety edge control by optoelectronic sensor (sensor located inside the rubber profile), self-monitored.
Emergency operation	Mechanically via hoist chain.